

CDG INTERNATIONAL ROAMING TEAM

Theme: Smartphones and their impact on CDMA Data Roaming

April 27-29, 2011

Nanjing, China

IPX for Data Roaming

Art Stoutenburg

Group Product Manager

Syniverse



Syniverse: Who We Are

- Global provider of market-leading solutions that simplify the complexities of roaming, messaging, network interoperability and business intelligence for operators, MSOs, enterprise verticals and emerging mobile providers
- Leading provider of SS7 network and database services for over 20 years
- More than 1,400 employees in 25 countries around the world; about 850 in North America. Headquartered in Tampa, Florida
- \$640M+ USD(est) in 2010 revenues
- The Carlyle Group acquired Syniverse Technologies for \$2.6B USD

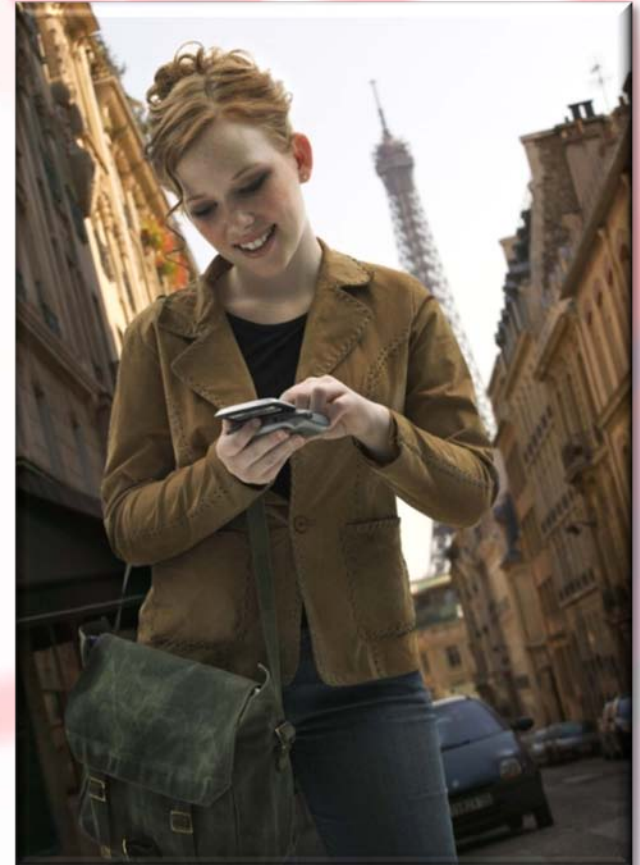

Why We Are Here Today

- 1984 Motorola Dyna TAC 8000X
- Weight - Two pounds (.908 Kg)
- Cost - \$3,995 USD or 25,956 CNY



Past to Present

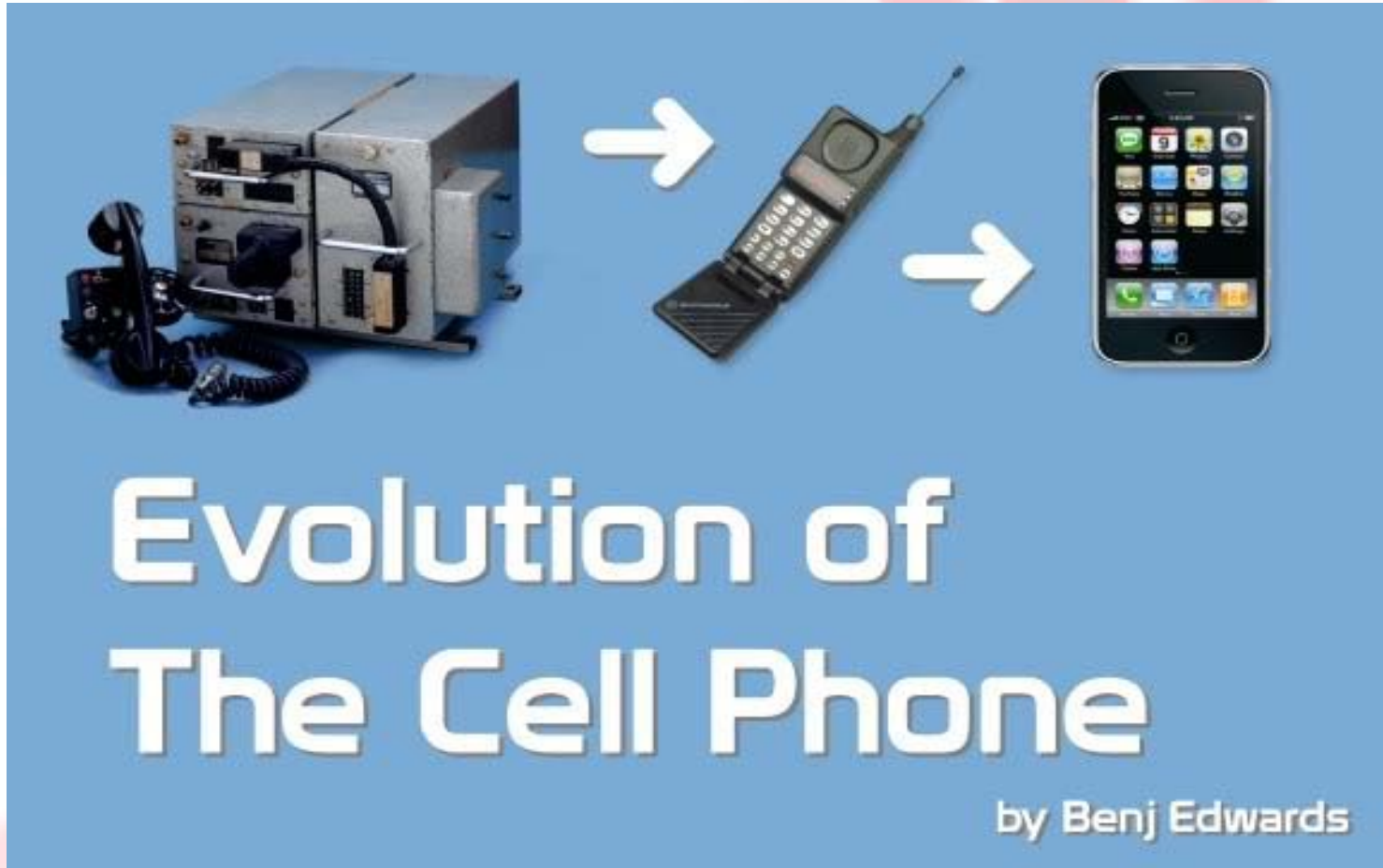

IPX Purpose

What are we trying to resolve?

- Industry convergence
- Transition and integration to IP infrastructure
- Migration from legacy to ALL IP/LTE
- Transparency of devices and services globally
- Improved quality of service (QoS)/quality of experience (QoE)
- Improved efficiency

Network Evolution

IPX (service agnostic)

- QoS guarantees
- Class of Service (CoS) (Conversational, Streaming, Interactive, Background)
- Complete integration with GRX/CRX and EGRX/ECRX
- Multi-service environment, convergence of (EGRX, ECRX, Signaling, VOIP, Messaging, LTE, IMS)
- Advanced Network Monitoring

EGRX/ECRX

- QoS guarantees
- CoS capability
- New customers going forward
- Advanced Network Monitoring

GRX/CRX

- QoS guarantees
- Proven performance over 10+ years
- Managed by capacity, no network congestion
- Network Monitoring

1999

2010

2020

Timeline

Technology
Migration
Path

Key Industry Trends

- Rise of the **mobile lifestyle**
 - Growth in smartphone penetration and multi-mode devices
 - Wireless data and messaging continue exponential growth
- Converged services
 - new players in the wireless market
- Migration to IP-centric services
- Consolidation, growth of multinational operators
- Evolution to LTE

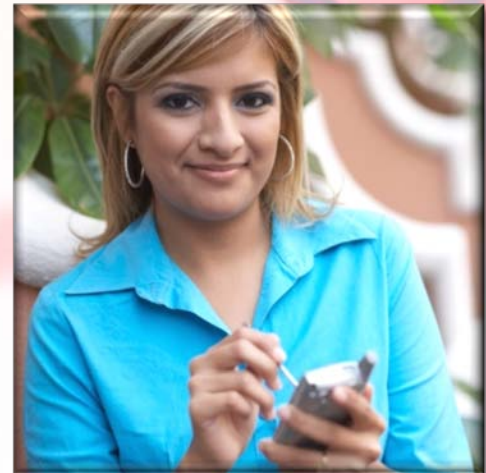

Voice & Data Growth

- In 2007 voice was 95% of the traffic while data was only 5%
- In Q4 2009, voice and data were almost equal
- In Q2 2010, data exceeded voice by 30%
- By 2015 data is expected to grow by 10-fold

Multi-Layered Approach

Full service provider

- Hub features: clearing/settlement, reporting, billing, agreement management, end-to-end quality

Layering on value

- Services: voice, SMS, MMS, GRX, CRX, video calling, signaling, ENUM, etc.

Foundation

- Transport: IPX- carrier grade, SLAs, CoS, QoS

Why IPX for Data Roaming?

- Class of Service (CoS) is supported over the IPX
- IPX is a private IP network with **less hops** to the end destination
- Data can be marked as EF (expedite forwarding) to ensure **minimum** latency through the network
- SLAs are supported for data over the IPX

Enhanced CRX

- Enhanced CRX
 - QoS guarantees
 - Packet Loss (<.1%), Latency (location dependant), Availability (99.999%), Jitter (5ms Intra-continent, 10ms Inter-continent, 20ms peering)
 - CoS capability
 - 4 traffic classes (Conversational, Streaming, Interactive, Background)
 - Provides for traffic prioritization by type and need
 - Operator direct connections
 - QoS supported
 - CoS included – EF

CRX/GRX vs. IPX Network SLAs

SLA Element	ECRDX/EGRX/IPX	CRX/GRX
Availability: Core	99.995%	99.95%
Availability: Single Customer Connection	99.7%	99.7%
Availability: Dual Customer Connection	99.9%	99.9%
Delay	See tables	400ms one way
Packet Loss	(Per Diffserv PHB) EF = Less than 0.1% AF1 Less than 0.1% AF3 = .08% AF4 = 0.1% BE = Less than 0.3%	Less than 0.3%
Jitter	5ms Intra-continent 10ms inter-continent 20ms peering	Not Available

EF = Expedited Forwarding
 AF= Assured Forwarding
 BE = Best Effort

GRX/CRX vs. IPX Reporting

Element	Description	GRX/CRX	EGRX/IPX
Availability	The percentage of time the network connection has been available/on-line processing data	No	Yes
Utilization	The relative utilization of the network connection, measured in Mb/sec separately for transmit and receive	Yes	Yes
Packet Loss	The percentage of IP packets lost in transit	Yes	Yes
Delay	Packet transfer delay, measured in milliseconds	Yes	Yes
Jitter	Packet delivery variance, measured in milliseconds	No	Yes

Network Monitoring & Reporting

- Service provisioning includes class/quality of service options
- Network monitoring tools offer visibility to all quality elements
- Monitoring tools emphasize network capacity planning, SLA management

CRX Managed IP Network

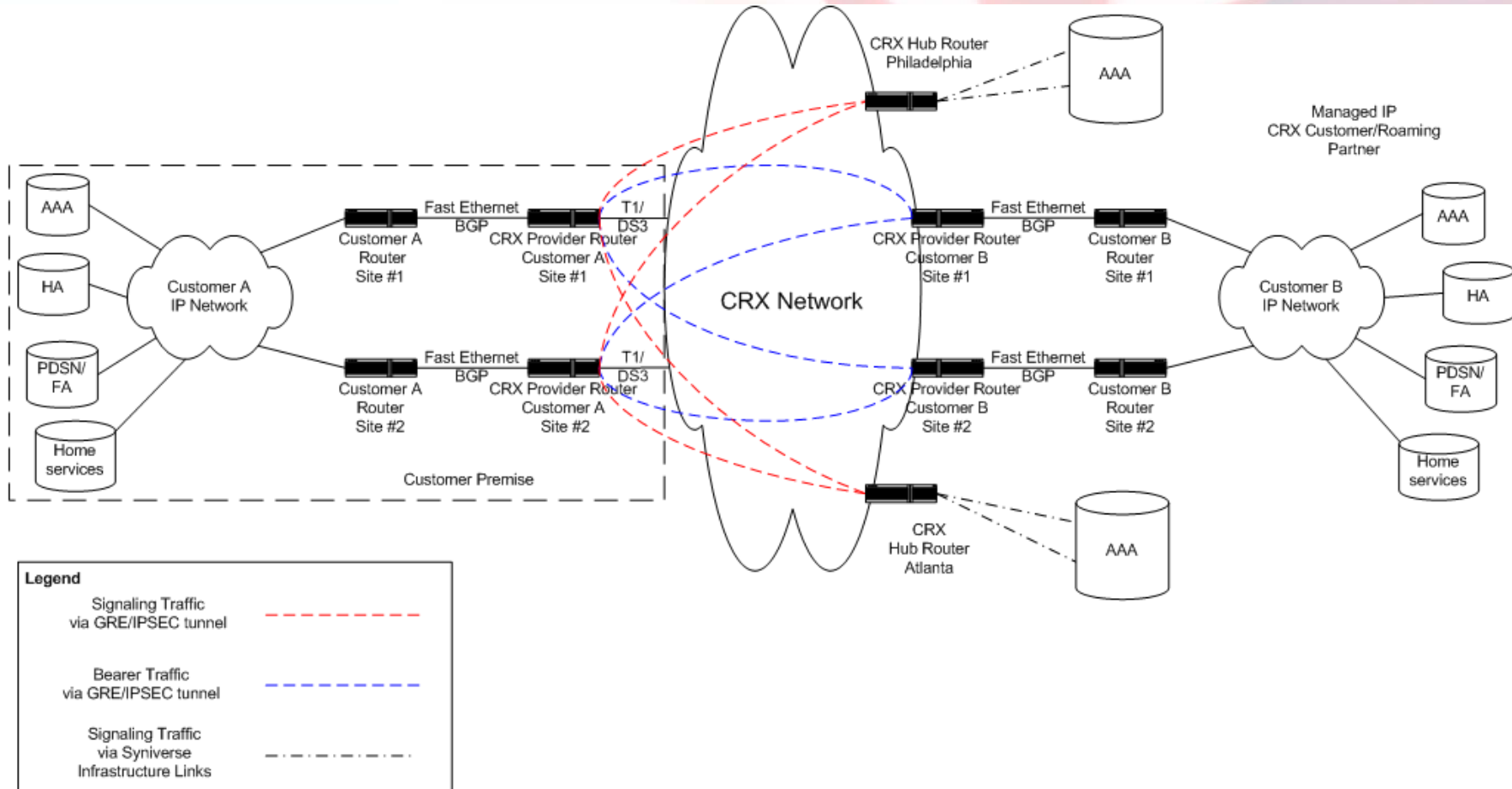

- CRX Provider provides managed routers and network connections at customer premise
- GRE/IPSEC/3DES tunnels built from customer sites to CRX sites for signaling traffic
- CRX provides signaling and bearer traffic routing to other CRX customers (roaming partners) via CRX network
- BGP peering used between CRX Provider and customers
- Public Autonomous System numbers required on all BGP peers
- As new roaming partners are established, CRX Provider will create meshed IPSEC/GRE/3DES to each location as requested by customers
- Managed IP network supported at data rates of DS1 and greater (based on customer's data roaming estimates)

GRX/CRX Evolving to IPX

IPX is not just for CRX/GRX

GRX/CRX
Distributed Network

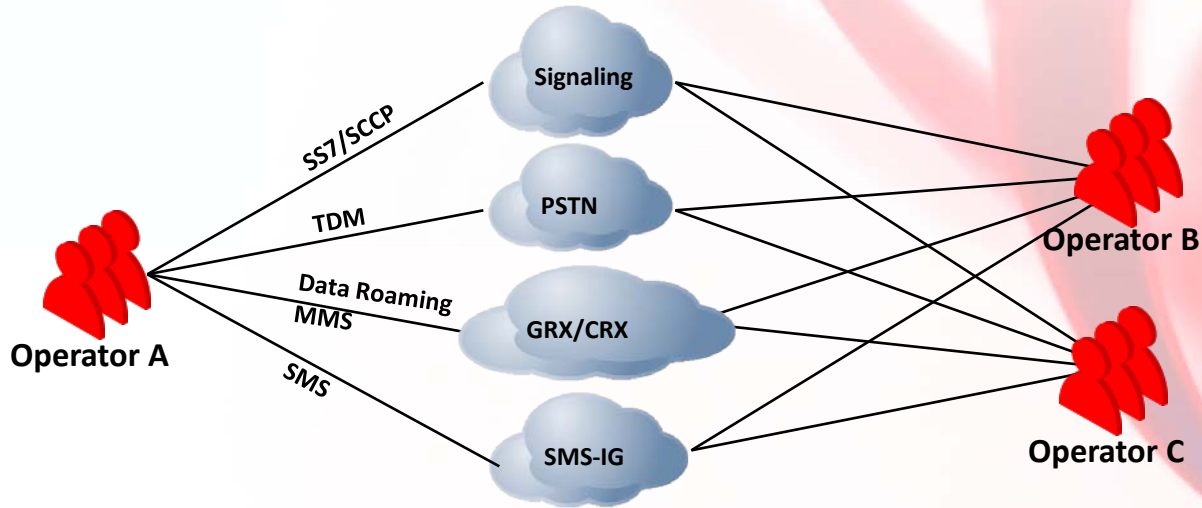

- Multiple networks
- Multiple contracts
- No new IP services
- Long time to market of new services

IPX
Converged Network

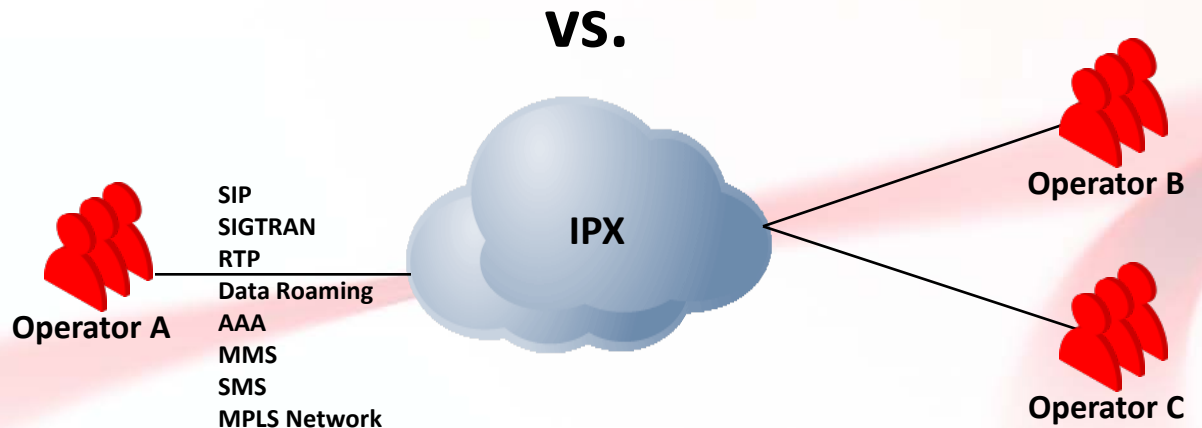

- One network
- One contract
- New IP services
- Short time to market of new services – packet voice, video share/calling, PoC, IM

IPX: Converged Services

Multiple services over one network

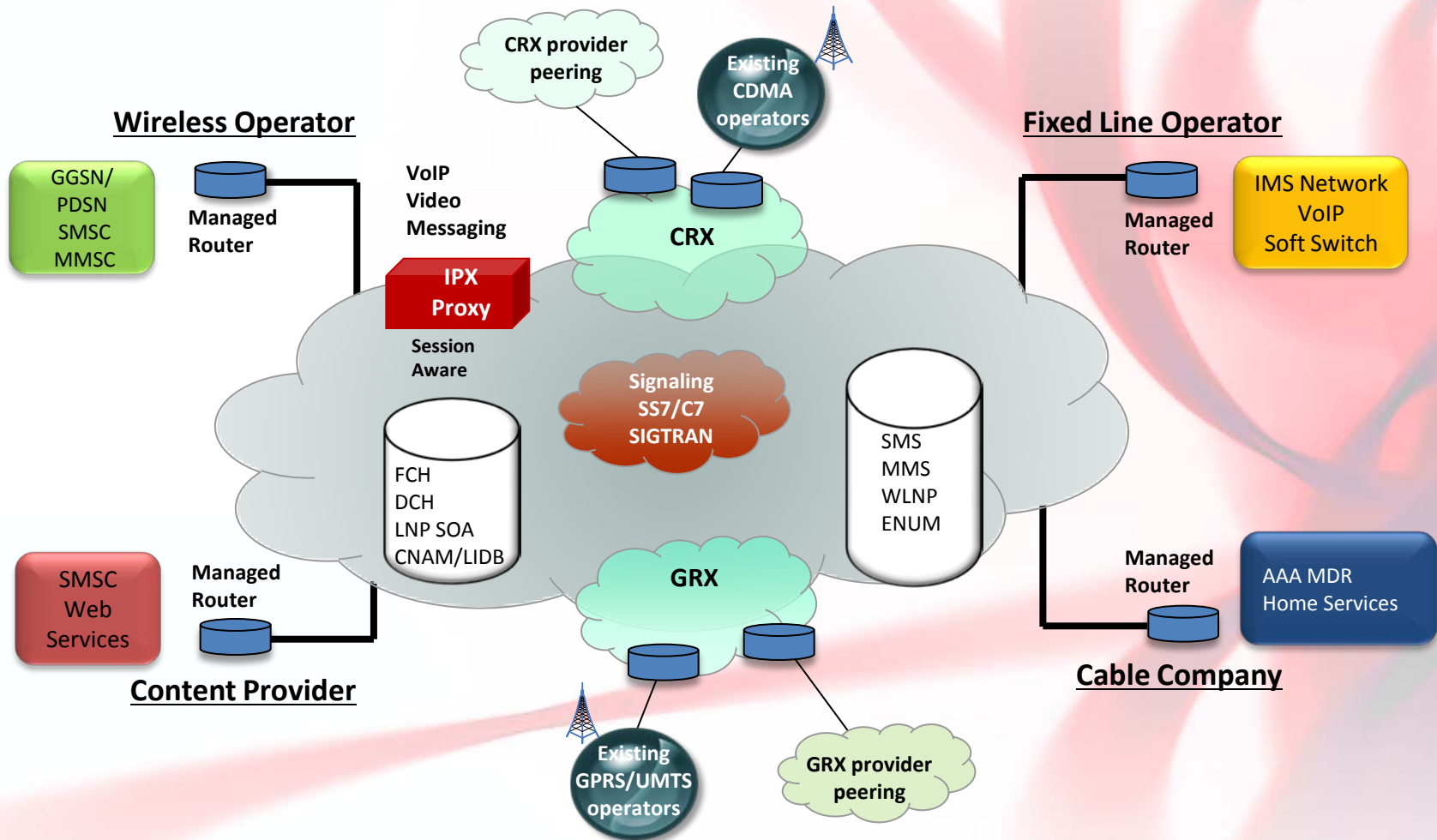

Many Mobile Operators Launching IPX for Data Roaming

- North America mobile operators are migrating their CRX/GRX over IPX and then migrating their SS7 signaling
- Several Asia Pacific mobile operators also are migrating their CRX/GRX over to IPX and then investigating voice transport

IPX for Data Roaming Challenges

- CRX/GRX has defined peering locations but IPX may not
- Will IPX providers support all SLAs in IR.34?
- Can you justify IPX for data roaming only?
 - May need business case for CRX, signaling, SMS, and data clearing to identify costs savings

IPX for Data Roaming Considerations

- What does my business case tell me?
- Do I want my customers to have an improved experience with their data applications?
- Is having access to multiple application service providers (ASPs) an advantage for me to remain more competitive?
- Can my current network infrastructure keep pace with the demand of data?

A decorative graphic of a red ribbon swirling across the right side of the slide, starting from the top right and moving towards the bottom left.

Thank You

Art Stoutenburg
Group Product Manager – Syniverse
art.stoutenburg@syniverse.com